

# High-Tech Range

CSPC

MRG2- Generator-mains monitor/Vector surge Relay





<b>1. Introduction and application</b>	
<b>2. Features and characteristics</b>	
<b>3. Design</b>	
3.1.1 Analog input circuits	
3.1.2 Output relays	
3.1.3 Blocking input	
3.1.4 Reset input	
3.2 Display	
3.3 Front plate	
3.4 LEDs	
<b>4. Working principle</b>	
4.1 Analog circuits	
4.2 Digital circuits	
4.3 Selection of star or delta connection	
4.4 Vector surge supervision	
4.4.1 Measuring principle of vector surge supervision	
4.5 Voltage threshold for vector surge measuring	
4.6 Blocking function	
<b>5. Operation and setting</b>	
5.1 Adjustable parameters	
5.2 Setting procedure	
5.2.1 Parameter setting of vector surge supervision	
5.2.2 Voltage threshold for vector surge measuring	
5.2.3 Adjustment of the slave address	
5.3 Indication of measuring values	
5.3.1 Min./Max.- values	
5.4 Reset	
<b>6. Relay testing and commissioning</b>	
6.1 Power-On	
6.2 Testing the output relays and LEDs	
6.3 Checking the set values	
6.4 Secondary injection test	
6.4.1 Test equipment	
6.4.2 Checking the vector surge function	
6.4.3 Checking the external blocking and reset functions	
6.5 Primary injection test	
6.6 Maintenance	
<b>7. Technical data</b>	
7.1 Measuring input circuits	
7.2 Common data	
7.3 Setting ranges and steps	
<b>8. Order form</b>	

## 1. Introduction and application

The vector surge relay **MRG2** protects synchronous generators in mains parallel operation due to very fast decoupling in case of mains failure.

Very dangerous are mains auto reclosings for synchronous generators. The mains voltage returning after 300 ms can hit the generator in asynchronous mode.

A very fast decoupling is also necessary in case of long lasting mains failures.

## 2. Features and characteristics

- Microprocessor technology and watchdog
- Effective analog low pass filter for suppressing harmonics when measuring vector surge
- Digital filtering of the measured values by using discrete Fourier analysis to suppress the high frequency harmonics and d.c. components induced by faults or system operations
- Adjustable voltage threshold for blocking vector surge measuring.
- Display of all measuring values and setting parameters for normal operation via an alphanumeric display and LEDs
- Storage and indication of the tripping values
- In compliance with VDE 0435, part 303 and IEC 255
- Vector surge tripping 1-of-3 or 3-of-3 adjustable

### 3. Design

#### 3.1 Connections

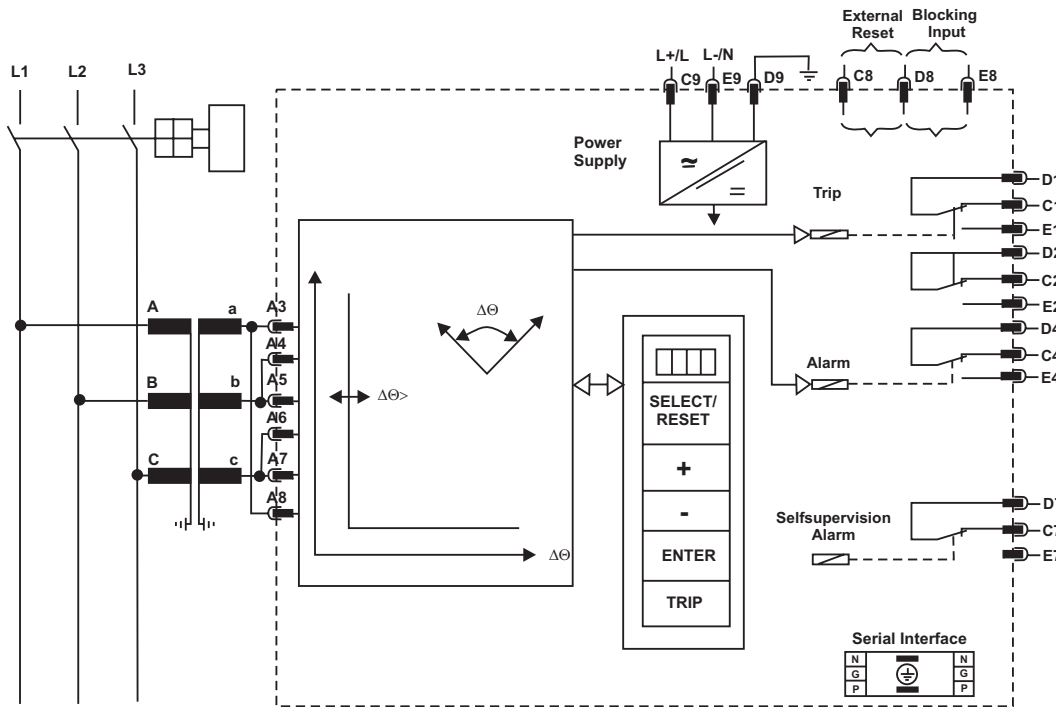

Fig.3.1: Connection diagram MRG2

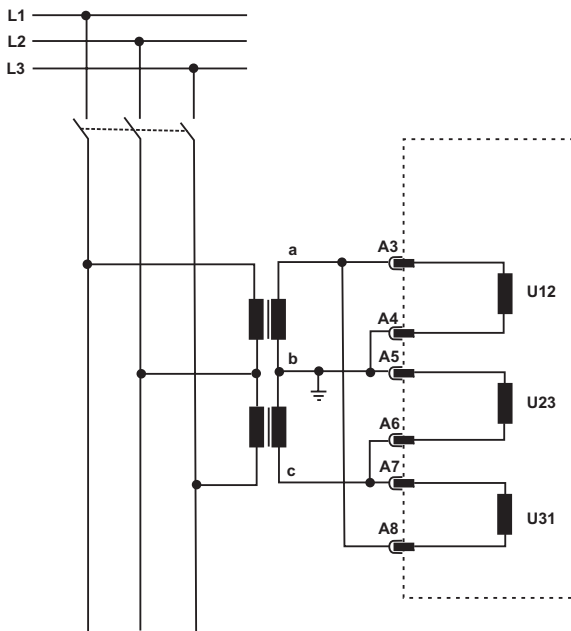

Fig 3.2: Voltage transformer in V-connection

##### 3.1.1 Analog input circuits

The analog input voltages are galvanically decoupled by the input transformers of the device, then filtered and

finally fed to the analog digital converter. The measuring circuits can be connected to the relay in Y or D connection.

##### 3.1.2 Output relays

The **MRG2** has 3 output relays. The tripping relay is equipped with two changeover contacts and the two indication relays each with one changeover contact.

- Tripping C1, D1, E1 and C2, D2, E2
- Indication of vector surge alarm C4, D4, E4
- Indication self supervision (internal fault of the unit) C7, D7, E7

All trip and alarm relays are normally-off relays, the relay for self supervision is a normally-on relay.

##### 3.1.3 Blocking input

If the auxiliary voltage is applied to D8/E8, the vector surge function is blocked as described in chapter 4.5.

##### 3.1.4 Reset input

Please refer to chapter 5.4.

### 3.2 Display

Function	Display shows	Pressed pushbutton	Corresponding LED
Normal operation	CSPC		
Measured operating values	Actual measured value $U, f, f_{min}, f_{max}$ $\Delta\theta, \Delta\theta_{min}, \Delta\theta_{max}$	<SELECT/RESET> one time for each value	$\Delta\theta, L1, L2, L3, f, min,$ max
Y/ $\Delta$ -connection	Y / DELT	<SELECT/RESET><+><->	Y/ $\Delta$
1-of-3/3-of-3 vector surge tripping threshold for vector surge	1Ph/3Ph Setting value in degree	<SELECT/RESET><+><-> <SELECT/RESET><+><->	1/3 $\Delta\theta$
Blocking	EXIT	<+> until max. setting value <-> until min. setting value	LED $\Delta\theta$
Voltage threshold for vector surge measuring	Setting value in volt	<SELECT/RESET><+><->	$U_b$
Slave address of serial interface	1 - 32	<SELECT/RESET><+><->	RS
Vector surge angle at tripping	Tripping value in degree	<SELECT/RESET><+><->	$\Delta\theta + L1, L2$ or L3
Save parameter?	SAV?	<ENTER>	
Save parameter!	SAV!	<ENTER> for about 3 s	
Software version		<TRIP> one time for each part	
Manual trip	TRI?	<TRIP> three times	
Inquire password	PSW?	<SELECT/RESET>/ <+>/<->/<ENTER>	
Relay tripped	TRIP	<TRIP> or fault tripping	
Secret password input	XXXX	<SELECT/RESET>/ <+>/<->/<ENTER>	
System reset	CSPC	<SELECT/RESET> for about 3 s	

Table 3.1: possible indication messages on the display

### 3.3 Front plate

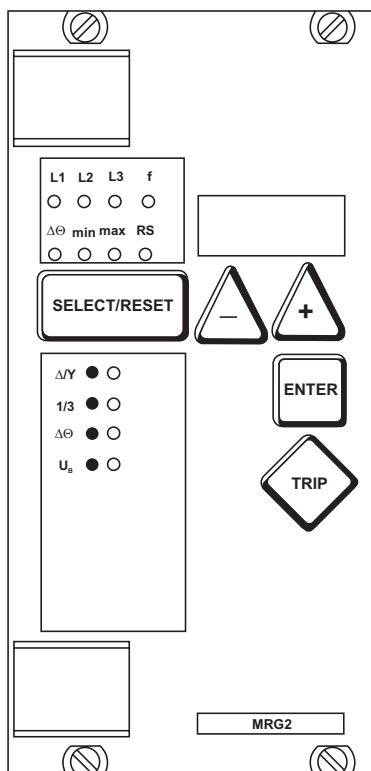

Fig. 3.3: Front plate MRG2

### 3.4 LEDs

All LEDs (except LED RS, min and max) are two-coloured. The LEDs on the left side, next to the alphanumerical display light up green during measuring and red after tripping.

The LEDs below the push button <SELECT/RESET> light up green during setting and inquiry procedure of the setting values which are printed on the left side next to the LEDs.

The LED marked with letters RS lights up during setting of the slave address of the device for serial data communication.

## 4. Working principle

### 4.1 Analog circuits

The input voltages are galvanically insulated by the input transformers. The noise signals caused by inductive and capacitive coupling are suppressed by an analog R-C filter circuit.

The analog voltage signals are fed to the A/D-converter of the microprocessor and transformed to digital signals through Sample- and Hold- circuits. The analog signals are sampled with a sampling frequency of  $16 \times f_{N'}$ , namely, a sampling rate of 1.25 ms for every measuring quantity. (by 50 Hz)

### 4.2 Digital circuits

The essential part of the **MRG2** relay is a powerful microcontroller. All of the operations, from the analog digital conversion to the relay trip decision, are carried out by the microcontroller digitally. The relay program is located in an EPROM (Electrically-Programmable-Read-Only-Memory). With this program the CPU of the microcontroller calculates the three phase voltages in order to detect a possible fault situation in the protected object.

For the calculation of the voltage value an efficient digital filter based on the Fourier Transformation (DFFT-Discrete Fast Fourier Transformation) is applied to suppress high frequency harmonics and d.c. components caused by fault-induced transients or other system disturbances. The microprocessor continuously compares the measured values with the preset thresholds stored in the parameter memory (EEPROM).

The relay setting values for all parameters are stored in a parameter memory (EEPROM - Electrically Erasable Programmable Read Only Memory), so that the actual relay settings cannot be lost, even if the power supply is interrupted.

The microprocessor is supervised by a built-in "watchdog" timer. In case of a failure the watchdog timer resets the microprocessor and gives an alarm signal via the output relay "self supervision".

### 4.3 Selection of star or delta connection

All connections of the input voltage transformers are led to screw terminals. The nominal voltage of the device is equal to the nominal voltage of the input transformers. Dependent on the application the input transformers can be connected either in delta or star. The connection for the phase-to-phase voltage is the delta connection. In star connection the measuring voltage is reduced by  $1/\sqrt{3}$ . During parameter setting the connection configuration either Y or  $\Delta$  has to be adjusted.

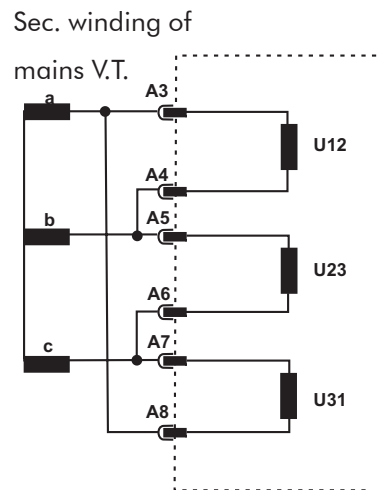

Fig. 4.1: Input v.t.s in delta connection ( $\Delta$ )

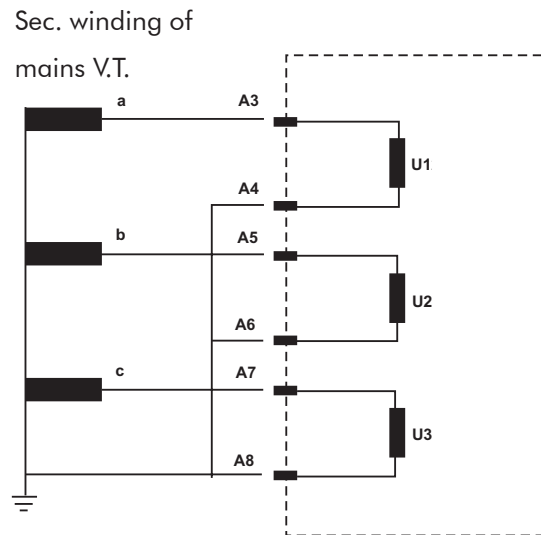

Fig. 4.2: Input v.t.s in star connection (Y)

## 4.4 Vector surge supervision

The vector surge supervision protects synchronous generators in mains parallel operation due to very fast decoupling in case of mains failure. Very dangerous are mains auto reclosings for synchronous generators. The mains voltage returning after 300 ms can hit the generator in asynchronous mode. A very fast decoupling is also necessary in case of long lasting mains failures. Generally there are two different applications:

- a) Only mains parallel operation no single operation:  
In this application the vector surge supervision protects the generator by tripping the generator circuit breaker in case of mains failure.
- b) Mains parallel operation and single operation:  
For this application the vector surge supervision trips the mains circuit breaker. Here it is insured that the gen.-set is not blocked when it is required as the emergency set.

A very fast decoupling in case of mains failures for synchronous generators is known as very difficult. Voltage supervision units cannot be used because the synchronous alternator as well as the consumer impedance support the decreasing voltage.

For this the mains voltage drops only after some 100 ms below the pickup threshold of voltage supervision relays and therefore a safe detection of mains auto reclosings is not possible with this kind of relay.

Frequency relays are partial unsuitable because only a highly loaded generator decreases its speed within 100 ms. Current relays detect a fault only when shortcircuit type currents exist, but cannot avoid their development. Power relays are able to pickup within 200 ms, but they too cannot prevent power to rise to short-circuit values. Since power changes are also caused by sudden loaded alternators, the use of power relays can be problematic.

Whereas the **MRG2** detects mains failures within 60 ms without the restrictions above because they are specially designed for applications where very fast decoupling from the mains is required.

Adding the operating time of a circuit breaker or contactor, the total disconnection time remains below 150 ms. Basic requirement for tripping of the generator/ mains monitor is a change in load of more than 15-20 % of the rated load. Slow changes of the system frequency, for instance at regulating processes (adjustment of speed regulator) do not cause the relay to trip.

Trippings can also be caused by short-circuits within, the grid, because a voltage vector surge higher than the preset value can occur. The magnitude of the voltage vector surge depends on the distance between the short-circuit and the generator. This function is also of advantage to the Power Utility Company because the mains short-circuit capacity and consequently the energy feeding the short-circuit is limited.

To prevent a possible false tripping the vector surge measuring can be blocked at a set low input voltage (refer to 5.2.2).

Vector surge tripping is blocked by a phase loss so that a VT fault (e.g. faulty VTs fuse) does not cause false tripping.

When switching on the aux. voltage or measuring voltage , the vector surge supervision is blocked for 5 s (refer to chapter 4.5).

Note:

In order to avoid any adverse interference voltage effects, for instance from contactors or relays, which may cause overfunctions, **MRG2** should be connected separately to the busbar.



### 4.4.1 Measuring principle of vector surge supervision

When a synchronous generator is loaded, a rotor displacement angle is built between the terminal voltage (mains voltage  $\underline{U}_1$ ) and the synchronous internal voltage ( $\underline{U}_p$ ). Therefore a voltage unit difference  $\Delta U$  is built between  $\underline{U}_p$  and  $\underline{U}_1$  (Fig. 4.1).

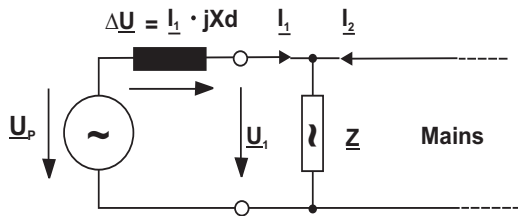

Fig. 4.1: Equivalent circuit at synchronous generator in parallel with the mains

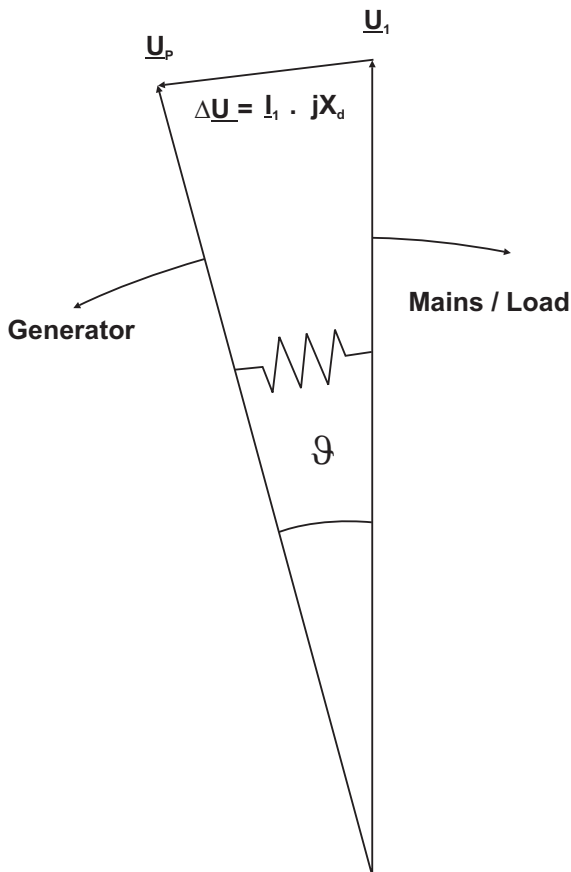

Fig. 4.2: Voltage vectors at mains parallel operation

The rotor displacement angle  $J$  between stator and rotor is depending of the mechanical moving torque of the generator shaft. The mechanical shaft power is balanced with the electrical feeded mains power, and therefore the synchronous speed keeps constant (Fig. 4.2).

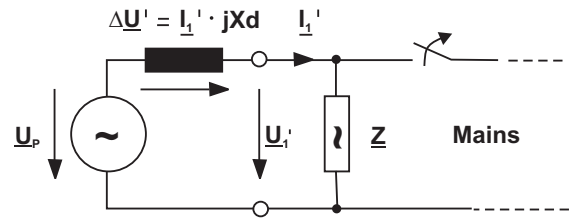

Fig. 4.3: Equivalent circuit at mains failure

In case of mains failure or auto reclosing the generator suddenly feeds a very high consumer load. The rotor displacement angle is decreased repeatedly and the voltage vector  $\underline{U}_1$  change its direction ( $\underline{U}_1'$ ) (Fig. 4.3 and 4.4).

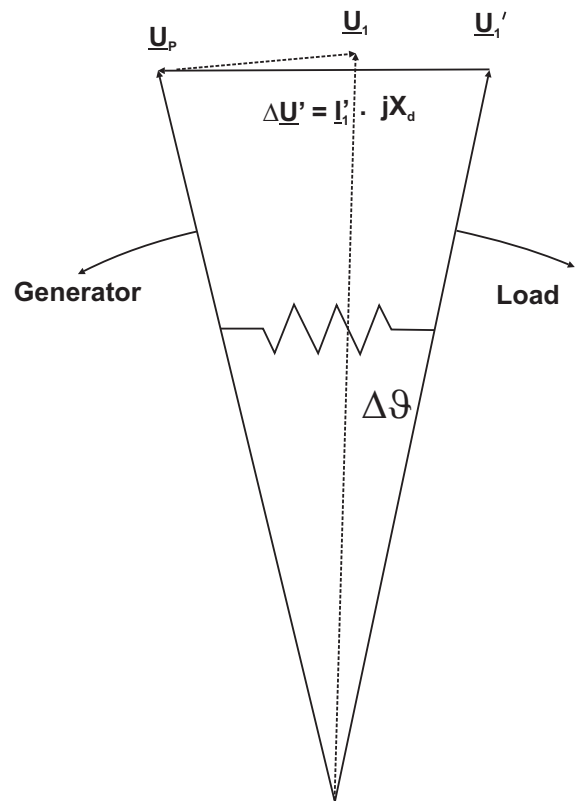
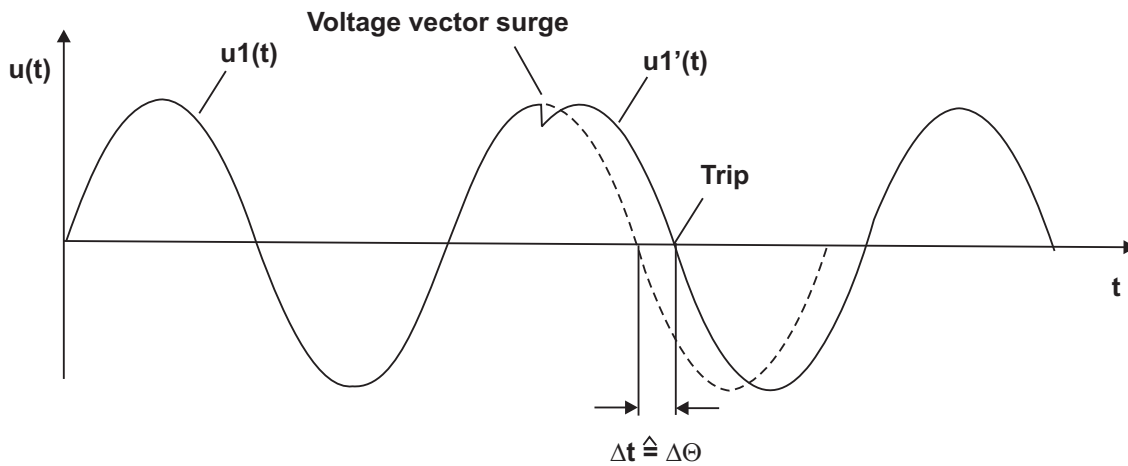

Fig. 4.4: Voltage vectors at mains failure



**Fig. 4.5: Voltage vector surge**

As shown in the voltage/time diagram the instantaneous value of the voltage jumps to another value and the phase position changes. This is named phase or vector surge.

The **MKG2** measures the cycle duration. A new measuring is started at each voltage zero passage. The measured cycle duration is internally compared with a quartz stable reference time and from this the deviation of the cycle duration of the voltage signal is ascertained. In case of a vector surge as shown in fig. 4.5, the zero passage occurs either earlier or later. The established deviation of the cycle duration is in compliance with the vector surge angle.

If the vector surge angle exceeds the set value, the relay trips immediately.

Tripping of the vector surge is blocked in case of loss of one or more phases of the measuring voltage.

Tripping logic for vector surge measurement:

The vector surge function of the **MKG2** supervises vector surges in all three phases at the same time. Tripping of the relay can be adjusted for an one phase vector surge (more sensitive measurement). For this the parameter 1/3 has to be set to "1Ph". When the parameter 1/3 is set to "3Ph", tripping of the vector surge element occurs only if the vector surge angle exceeds the set value in all three phases at the same time.

## Application hint

Although the vector surge relay guarantees very fast and reliable detection of mains failures under nearly all operational conditions of mains parallel running alternators, the following borderline cases have to be considered accordingly:

a) None or only insignificant change of power flow at the utility connection point during mains failures.

This can occur during peak lopping operation or in CHP stations (Combined Heat and Power) where the power flow between power station and the public grid may be very low. For detection of a vector surge at parallel running alternators, the load change must be at least 15 - 20 % of the rated power. If the active load at the utility connection point is regulated to a minimal value and a high resistance mains failure occurs, then there are no vector surge nor power and frequency changes and the mains failure is not detected.

This can only happen if the public grid is disconnected near the power station and so the alternators are not additionally loaded by any consumers. At distant mains failures the synchronous alternators are abruptly loaded by remaining consumers which leads directly to a vector surge and so mains failure detection is guaranteed.

If such a situation occurs the following has to be taken into account:

In case of an undetected mains failure, i.e. with the mains coupling C.B. closed, the vector surge relay reacts upon the first load change causing a vector surge and trips the mains C.B.

For detecting high resistance mains failures a minimum current relay with an adjustable trip delay can be used. A trip delay is needed to allow regulating actions where the current may reach "zero" at the utility connection point. At high resistance mains failures, the mains coupling C.B. is tripped by the minimum current relay after the time delay.

To prevent asynchronous switching on, an automatic reclosing of the public grid should be not possible during this time delay.

A further measure could be, that the load regulation at the utility connection point guarantees a minimum power flow of 15 - 20 % of rated power.

b) Short circuit type loading of the alternators at distant mains failures

At any distant mains failure, the remaining consumers cause sudden short circuit type loading of the power station generators. The vector surge relay detects the mains failure in about 60 ms and switches off the mains coupling C.B. The total switch off time is about 100 - 150 ms. If the generators are provided with an extremely fast short circuit protection e.g. able to detect  $di/dt$ , the alternators might be switched off unselectively by the generator C.B., which is not desirable because the power supply for the station is endangered and later on synchronized changeover to the mains is only possible after manual reset of the overcurrent protection.

To avoid such a situation, the alternator C.B.s must have a delayed short circuit protection. The time delay must be long enough so that mains decoupling by the vector surge relay is guaranteed.

#### 4.5 Voltage threshold for vector surge measuring

At low measuring voltages, e.g. during generator start-up, vector surge measuring is perhaps not desired.

By means of the adjustable voltage threshold  $U_B \Delta\theta$  is blocked if the measured voltage falls below the set value.

#### 4.6 Blocking function

Nr.	Dynamic Behaviour	$\Delta\theta$
1	voltage to external blocking input is applied	blocked
2	blocking input is released	blocked for 5 seconds
3	supply voltage is switched on	blocked for 5 seconds
4	3ph measuring volt. is suddenly applied	blocked for 5 seconds
5	one or several measuring voltages are switched off suddenly (phase failure)	blocked
6	measuring voltage $< U_B$ (adjustable voltage threshold)	blocked

**Table 4.1: Dynamic behaviour of MRG2 functions**

### 5. Operation and setting

#### 5.1 Adjustable parameters

The following parameters can be set by the user himself:

- Y/ $\Delta$  - Star/Delta change-over of the input transformer
- 1/3 - Vector surge tripping 1-of-3/3-of-3
- $\Delta\theta$  - Pickup value for vector surge in degree
- $U_B$  - voltage threshold for frequency and vector surge measuring (or  $df/dt$ )
- RS - Slave address of the serial interface

#### 5.2 Setting procedure

In this paragraph the settings for all relay parameters are described in detail. For parameter setting a password has to be entered first (please refer to 4.4 of description "MR-Digital Multifunctional Relays").

##### 5.2.1 Parameter setting of vector surge supervision

Both the vector surge angle  $\Delta\theta$  as well as the tripping logic concerning the vector surge have to be adjusted for a vector surge supervision.

If the tripping logic is set to 1-of-3 (= "1Ph" on the display), the relay trips as soon as the measured vector surge angle has exceeded the set value  $\Delta\theta$  in one of the three phases.

This is the more sensitive adjustment when compared with the three phase tripping logic 3-of-3 (= "3Ph" on the display), where tripping occurs only if the vector surge angle exceeds the set value in all three phases. We recommend to choose the one phase tripping logic "1Ph". Only if by this adjustment the respond to failures is too sensitive, adjustment "3Ph" should be used.

The recommended setting of the vector surge angle  $\Delta\theta$  in a low impedance mains is 4-6 degrees. This setting is sufficient in most cases, because low impedance mains do not have a vector surge greater than this value. In case of an auto reclosing, this value is exceeded.

In high impedance mains the setting should be 10° to 12° to avoid failure tripping when switching on or switching off big consumer loads.

The vector surge function of this device can be checked as follows:

- a) Generator in insulated operation: Switching off and on of loads (approx. 20 % of the nominal generator capacity) must trip the relay. Later in normal insulated operation the tripping of the relay is inhibited.
- b) In mains parallel operation switching on and switching off of consumers loads and controlling the governor of the prime mover should not trip the relay.

If possible the test described under a) and b) should be double checked by a real auto reclosing.

Threshold for the vector surge supervision

When the pickup value of the vector surge supervision is set, a value in angular degree is indicated at the display. The pickup value requested can be adjusted by pushbuttons <+> and <-> in the range of 2° to 22°. LED  $\Delta\theta$  lights up red during this procedure.

### 5.2.2 Voltage threshold for vector surge measuring

False tripping of the **MRG2** is prevented by an adjustable voltage threshold  $U_b$ . If the system voltage is below this threshold, the vector surge function of the relay is blocked.

During adjustment LEDs  $U_b$  lights up at the bottom of the display part.

### 5.2.3 Adjustment of the slave address

By pressing push buttons <+> and <-> the slave address can be set in the range of 1 - 32. During this adjustment the LED RS lights up.

## 5.3 Indication of measuring values

In normal operation the following measuring values can be displayed.

- Vector surge (LED DQ green)
- Voltage (LED L1, L2, L3)
  - U1, U2, U3 at Y-connection
  - U12, U23, U31 at D-connection

Min. and max.- values before the last reset:

- Frequency (LED f + min bzw. f + max)
- Vector surge (LED  $\Delta\theta$  + min bzw.  $\Delta\theta$  + max)

## 5.3.1 Min./Max.- values

The **MRG2** offers a minimum/maximum storage each for the measuring values of the vector surge as well as for frequency. These min./max. values are mainly used to appraise the system quality. Always the highest and lowest values of each cycle are measured and stored until the next reset.

Dependent on the adjustment of the tripping logic (1Ph or 3Ph), it is possible that the stored min./max. values are higher than the tripping threshold without causing a trip.

These min./max. measurements are of great advantage for long-term analysis of the grid quality.

As to operation :

After each reset (ref. 5.4) the min./max. storages are cleared. As from this instant there is no time limit for the min./max. storage until the next reset.

By repeatedly pressing the <SELECT/RESET> push button, the measuring values of the min./max. storage can be queried. The respective LEDs light up at the same time; e.g. minimum vector surge is displayed, LEDs " $\Delta\theta$ " and "min" light up.

## 5.4 Reset

All relays have the following three possibilities to reset the display of the unit as well as the output relay at jumper position J3=ON.

### Manual Reset

- Pressing the push button <SELECT/RESET> for some time (about 3 s)

### Electrical Reset

- Through applying auxiliary voltage to C8/D8

### Software Reset

- The software reset has the same effect as the <SELECT/RESET> push button

The display can only be reset when the pickup is not present anymore (otherwise "TRIP" remains in display).

During resetting of the display the parameters are not affected.

## 6. Relay testing and commissioning

The following test instructions should help to verify the protection relay performance before or during commissioning of the protection system. To avoid a relay damage and to ensure a correct relay operation, be sure that:

- the auxiliary power supply rating corresponds to the auxiliary voltage on site.
- the rated frequency and rated voltage of the relay correspond to the plant data on site.
- the voltage transformer circuits are connected to the relay correctly.
- all signal circuits and output relay circuits are connected correctly.

### 6.1 Power-On

#### NOTE!

Prior to switch on the auxiliary power supply, be sure that the auxiliary supply voltage corresponds to the rated data on the type plate. Switch on the auxiliary power supply to the relay and check that the message "CSPC" appears on the display and the self supervision alarm relay (watchdog) is energized (Contact terminals D7 and E7 closed).

### 6.2 Testing the output relays and LEDs

#### NOTE!

Prior to commencing this test, interrupt the trip circuit to the circuit breaker if tripping is not desired. By pressing the push button <TRIP> once, the display shows the first

part of the software version of the relay. By pressing the push button <TRIP> twice, the display shows the second part of the software version of the relay. The software version should be quoted in all correspondence. Pressing the <TRIP> button once more, the display shows "PSW?". Please enter the correct password to proceed with the test. The message "TRI?" will follow. Confirm this message by pressing the push button <TRIP> again. All output relays and LEDs should then be activated and the self supervision alarm relay (watchdog) be deenergized one after another with a time interval of 3 seconds. Thereafter, reset all output relays back to their normal positions by pressing the push button <SELECT/RESET>.

### 6.3 Checking the set values

By repeatedly pressing the push button <SELECT>, all relay set values may be checked. Set value modification can be done with the push button <+><-> and <ENTER>. For detailed information about that, please refer to technical description "MR - Digital Multifunctional Relays".

### 6.4 Secondary injection test

#### 6.4.1 Test equipment

- Voltmeter
- Auxiliary power supply with the voltage corresponding to the rated data on the type plate
- Three-phase voltage supply unit
- Timer to measure the operating time
- Switching device
- Test leads and tools

### 6.4.2 Checking the vector surge function

With the help of an advanced relay test equipment a phase shift (vector surge) on the voltage signal can be obtained to test the vector surge function of **MARG2** relay. If there is no such testing facility available, a very simple simulation circuit may be used to test the vector surge function of the relay with a sufficient accuracy. Figure 6.1 shows the possibility to simulate a phase shift by means of a RC circuit. Closing or opening the switch S1 causes the phase angle of the input voltage to change depending on the adjustable resistor R.

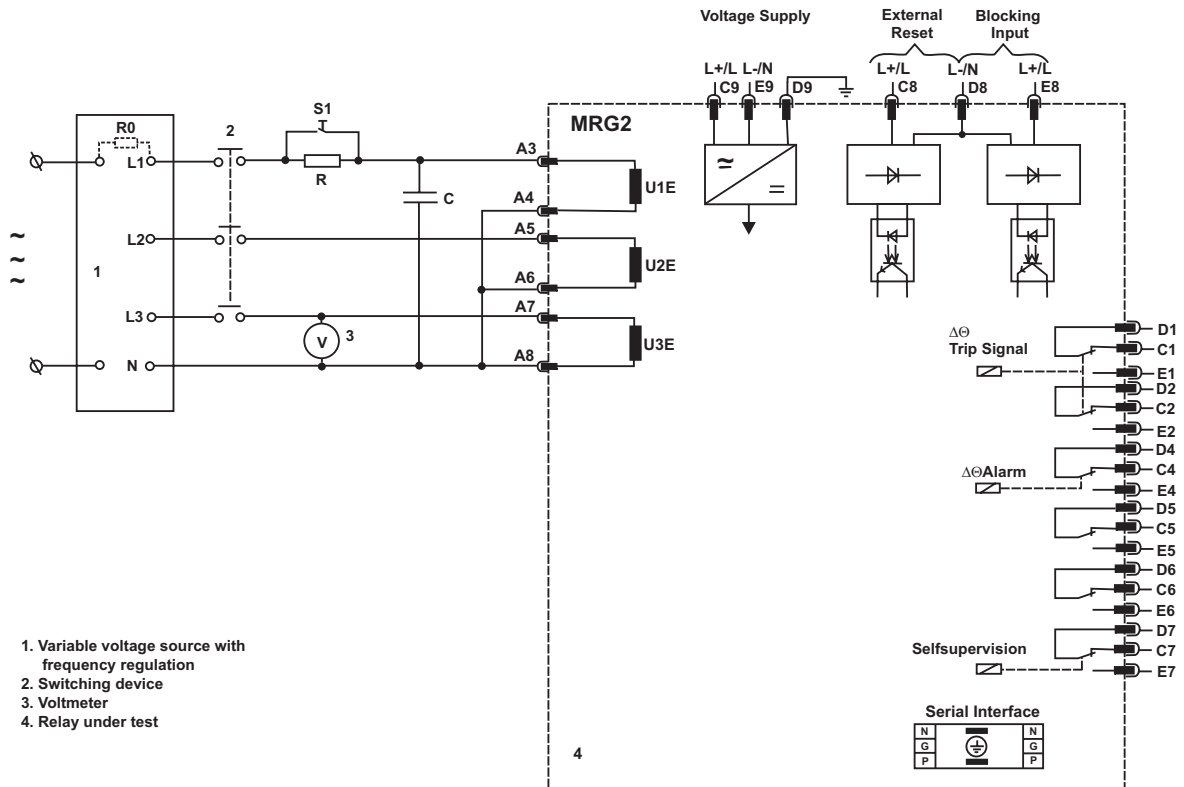

1. Variable voltage source with frequency regulation
2. Switching device
3. Voltmeter
4. Relay under test

**Fig. 6.1: Test circuit for the vector surge function**

The phase angle obtained may be calculated with the following formula and is almost independent on the test voltages.

In case of a 3-phase vector surge, the angle  $\Delta\theta$  can be calculated with the following formula if the parameters  $R_0$ , R and C are known:

$$\Delta\theta = \arctg \frac{1}{R_0 \cdot \omega \cdot C} - \arctg \frac{1}{(R_0 + R) \cdot \omega \cdot C}$$

Example :  $R_0 = 1 \text{ Ohm}$ ,  $R=363 \text{ Ohm}$ ,  $C=3 \mu\text{F}$

then :  $\Delta\theta = 90^\circ$

Usually the voltage source impedance  $R_0$  is negligible, hence  $R_0$  may be assumed zero. Thus, with a constant C, says  $3 \mu\text{F}$  (400 V AC), the value of R may be calculated using the following simplified formula:

$$\Delta\theta = 90^\circ - \arctg \frac{1}{R \cdot \omega \cdot C}$$

**Notel**

Using the above test circuit with single-phase vector surge, the resulting measured angle  $\Delta\theta$  is about half the value of  $\Delta\theta$  calculated for a 3-phase vector surge. To make tripping possible during a one phase test procedure, the vector surge tripping has to be set to "1Ph".

### 6.4.3 Checking the external blocking and reset functions

To test the blocking function for vector surge apply auxiliary supply voltage to the external blocking input of the relay (terminals E8/D8). Produce a vector surge which could cause tripping of the vector surge function. Observe that there is no trip and alarm.

Remove the auxiliary supply voltage from the blocking input. Apply test voltages to trip the relay (message „TRIP“ on the display). Apply auxiliary supply voltage to the external reset input of the relay (terminals C8/D8). The display and LED indications should be reset immediately.

### 6.5 Primary injection test

Generally, a primary injection test could be carried out in the similar manner as the secondary injection test described above. With the difference that the protected power system should be, in this case, connected to the installed relays under test „on line“, and the test voltages should be injected to the relay through the voltage transformers with the primary side energized. Since the cost and potential hazards are very high for such a test, primary injection tests are usually limited to very important protective relays in the power system.

Because of its powerful combined indicating and measuring functions, the **MRG2** relay may be tested in the manner of a primary injection test without extra expenditure and time consumption.

In actual service, for example, the measured voltage and frequency values on the **MRG2** relay display may be compared phase by phase with the concerned indications of the instruments of the switchboard to verify that the relay works and measures correctly.

## 6.6 Maintenance

Maintenance testing is generally done on site at regular intervals. These intervals vary among users depending on many factors: e.g. the type of protective relays employed; the importance of the primary equipment being protected; the user's past experience with the relay, etc.

For electromechanical or static relays, maintenance testing will be performed at least once a year according to the experiences. For digital relays like **MRG2**, this interval can be substantially longer. This is because:

- the **MRG2** relays are equipped with very wide self-supervision functions, so that many faults in the relay can be detected and signalled during service. Important: The self-supervision output relay must be connected to a central alarm panel!
- the combined measuring functions of **MRG2** relays enable supervision the relay functions during service.
- the combined TRIP test function of the **MRG2** relay allows to test the relay output circuits.

A testing interval of two years for maintenance will, therefore, be recommended.

During a maintenance test, the relay functions including the operating values and relay tripping times should be tested.



## 7. Technical data

### 7.1 Measuring input circuits

Rated data	:	Nominal voltage $U_N$	100 V, 230 V, 400 V
		Nominal frequency $f_N$	40 - 70 Hz
Power consumption in voltage circuit	:	< 1 VA	
Thermal rating	:	continuously	$2 \times U_N$
Undervoltage lockout for vector surge measurement	:	U < adjustable (5 %...100 % $U_N$ )	

### 7.2 Common data

Dropout time	:	60 ms
Time lag error class E	:	$\pm 10$ ms
Minimum operating time	:	50 ms
Max. allowed interruption of the auxiliary supply without affecting the function of the device	:	50 ms

### 7.3 Setting ranges and steps

Function	Parameter	Setting range	Steps	Tolerance
Connection of the input V.T.s	Y/ $\Delta$	Y/DELTA		
Vector surge logic	1/3	1Ph / 3Ph		
$\Delta\theta$	$\Delta\theta$	2°...22° (EXIT)	1°	$\pm 1^\circ$
Voltage threshold for vector surge measuring	$U_b$	$U_N = 100$ V: 5...100 V $U_N = 230$ V: 12...230 V $U_N = 400$ V: 20...400 V	1 V  1 V  2 V	$\pm 1$ % of set value or < 0.3 % $U_N$
Serial Interface	RS	1 - 32	1	

Table 7.1: Setting ranges and steps

**8. Order form**

Generator-/mains monitor		<b>MRG2—</b>				
Rated current	100 V	<b>1</b>				
	230 V	<b>2</b>				
	400 V	<b>4</b>				
Auxiliary voltage	24 V (16 to 60 V AC/16 to 80 V DC)	<b>L</b>				
	110 V (50 to 270 V AC/70 to 360 V DC)	<b>H</b>				
Serial interface RS485				<b>R</b>		
Housing (12TE)	19" rack					<b>A</b>
	Flush mounting					<b>D</b>

Technical data subject to change without notice!

## Setting list MRG2

Project: \_\_\_\_\_

Function group: = \_\_\_\_\_ Location: + \_\_\_\_\_

Relay code: \_\_\_\_\_

Relay functions: \_\_\_\_\_

Password: \_\_\_\_\_

Date: \_\_\_\_\_

Function		Unit	Default settings	Actual settings
Y/ $\Delta$	Selection of star or delta connection		Y	
1/3	Vector surge tripping logic		1 PH	
$\Delta\theta$	Vector surge tripping	$^\circ$	2.0	
$U_b <$	voltage threshold for vector surge measuring	V	10/23/40*	
RS	Slave address of serial interface		1	

\* Depends upon rated voltage.

Setting of code jumpers

Code jumper	J1		J2		J3	
	Default setting	Actual setting	Default setting	Actual setting	Default setting	Actual setting
Plugged						
Not plugged	X		X		X	



## **BASIC RANGE**

- Micro-controller based compact economical design
- DIN rail mounted
- Status indication via LED
- Step-less settings through front potentiometer



## **FUNCTIONAL RANGE**

- Genset Supervision & Control
- Auto Synchroniser
- Load Balancing & Control
- Related Protection



## **INTEGRATED RANGE**

- Complete numeric protection, solution for sub-station in association with TEAM-ARTECHE, Spain
- Distance protection
- Comprehensive transformer protection –
  - a. Three winding transformer
  - b. Two winding transformer
- Multi-functional relay: variety of protection combination

For further information, please contact :



### **C&S Protection & Control Ltd.**

44, Okhla Indl. Estate, New Delhi-110020, Ph.: 011-55602414, 26319465-66 Fax: 011-55602413 email: [cspc@controlsindia.com](mailto:cspc@controlsindia.com)

**Marketing Office : DELHI** : Ph.: 55602414, 26319465-66 Fax: 55602413 **CHANDIGARH** : Ph. 2776154, 2776151, 2726153 Fax: 2726154  
**KOLKATA** : Ph. 24549607-08 Fax: 24549371 **MUMBAI** : Ph.: 24114727-28 Fax : 24126631 **PUNE** : Ph.: 5444822-824, Fax: 5410820,  
**AHMEDABAD** : Ph.: 65841425, 6589132 Fax : 6589132 **BANGALORE** : Ph.: 5586147, 5323582, 5594939 Fax: 5582796,  
**CHENNAI** : Ph.: 26426475, 26426572 Fax: 26411972 **HYDERABAD** : Ph.: 27813003, 55332304 Fax: 27812987